

Equatorial Mount

EM-400

Temma 2

INSTRUCTION MANUAL

TAKAHASHI

Specifications

Equatorial Mount

Type:	German equatorial with Temma-2 go-to system built-in
R.A. slow motion:	Round worm wheel [180:1] by quartz controlled stepping motor
Dec. slow motion:	Round worm wheel [180:1] by quartz controlled stepping motor
Azimuth adjustment:	$\pm 10^\circ$ finely with dual screws 360° freely with the dedicated turntable
Altitude adjustment:	0°~47°(MAX 50°)
Loading capacity:	35kg (77 lbs)
Gross weight:	Main unit: 22.3kg (49 lbs) Head unit: 5.2kg (11 lbs) Weight shaft: 2.0kg(4.4 lbs)
Polar alignment scope	Built-in, 11x, 3' setting accuracy Scale pattern, quick reference type, good until 2040 in the Northern Hemisphere with illumination and bubble level
Counter-weight	8kg x2

Motor Drive System

[Temma2]

Drive System :	Dual axes, quartz control, driving frequency: 240pps N/S, Star/Sun switching by hand controller
Usable Area :	All over the world, but with limit for the latitude
High Speed Drive :	250X at DC12V 500X at DC24V
Correcting speed : (manual operation)	RA: 0.1 ~ 1.9x to the sidereal rate by 0.1x increments Dec: $\pm 1.5 \sim 13.5$ arc sec/sec by 1.5 arc sec/sec increments
Mode indicator:	High speed operation - red light Normal operation - green light
Power Source :	DC12V or DC24V
Power Consumption :	DC12V : 0.5/0.7A(1.6A) sidereal/high speed(start) DC24V : 0.4/0.9A(1.4A) Stand-by mood: 0.1A
Go-To Operation :	By a PC or Takahashi hand controller (THC)
Go-To Disc:	Pegasus 21
Accessory :	RS232C cable
Operational temperature:	-5 ~ +30°C

These specifications are subject to change without notice.

EM-400 Temma-2 Equatorial Mount

■ Equatorial Mount

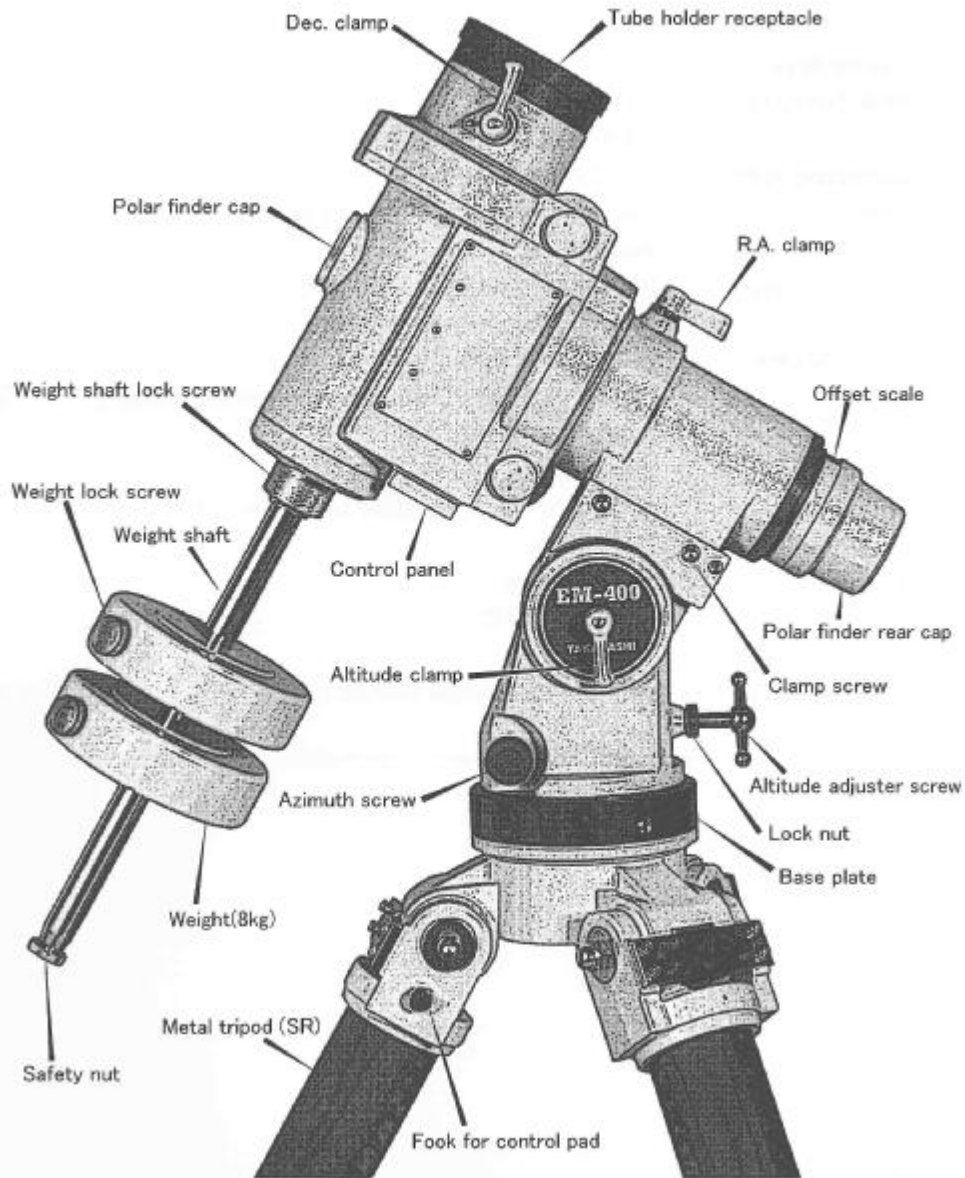
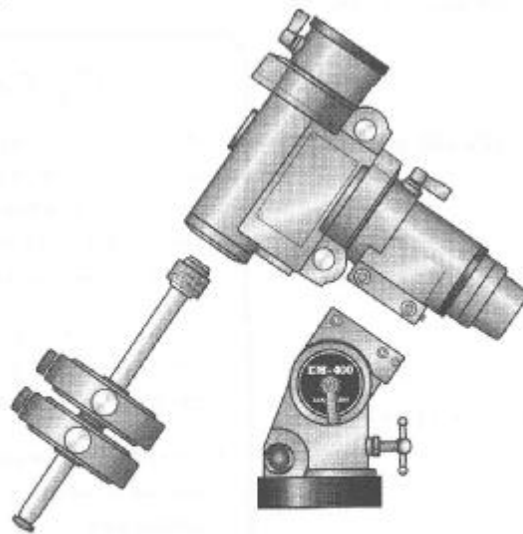

Fig.1

Features of the EM-400 Temma-2 Mount

- * Driving frequency at the sidereal rate is 240pps, which enables the EM-400 to operate the best possible capability even in observing planets with digital instruments.
- * More portability by the unit system. The main unit and the head unit can be separated for easy transport.
- * More rigidity than the NJP by using the worm wheel of the same diameter.
- * The quick reference scale pattern is used for the polar finder, which is 11x to assure the setting accuracy.
- * The new type of the tripod adapter is used when the mount is used with a wooden tripod. This adapter can turn the mount freely when setting.
- * The encoders are built in the R.A. and the Dec. housings for trouble-free transport.
- * The control box is placed on the bottom of the mount, which prevents the wirings from the connectors from being twisted at minimum.
- * The tube holder receptacle has 6 holes: 8mm x2 and 10mm x4. These holes will enable to attach all Takahashi tube holders and accessory plates.
- * Two lock screws are used for more firm locking the counter-weight on the straight shaft, which makes attaching and removing the weights easier.
- * Ideally matching with the Takahashi heavy-duty metal tripod.



Layout of the Control Panel

■ Control Panel

Power:

When the power switch and the Computer Stand By switch are flipped at the ON position, the power light turns orange. When the Computer Standby switch only is flipped to the ON position, the light turns green. When both switches are off, the light turns off.

P-Light Control:

The brightness of the illuminator can be adjusted by turning the P-light set screw. Turn the adjuster screw slowly to get proper brightness. A abrupt turning may cause the adjuster damaged.

Computer Stand By:

This is the switch that can memorize the current position of the mount when the motor is turned off. Before starting observation, turn the Computer Stand By switch on and then flip the motor switch to the ON position.

DC IN:

Power connector for 12V DC or 24V DC power source.

Control Box:

Hand control box connector receptacle.

RS-232C:

RS-232C cable, which connects the go-to mount to a PC, connector receptacle.

Auto Guide:

Auto guider cable connector.

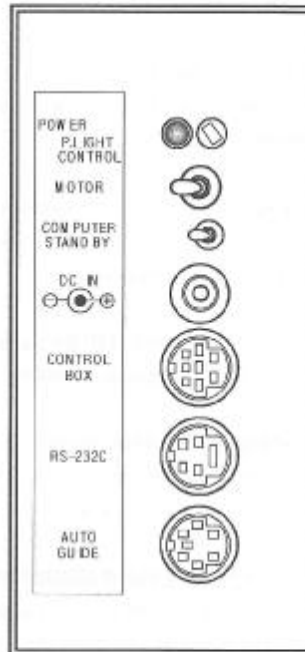

Fig. 2

⚠ Caution

- * When the Computer Stand By switch is turned off, the motor will not move regardless whether the motor switch is on or off and all settings will be cancelled to the starting function.
- * Do not push the switches into the circuit board. It might damage these switches and connectors.
- * Do not push the power plug past the normal position. It might damage the connectors.

Motor Drive Operation

■ Drive Correction

When the power is switched on, the motor is driven at the sidereal rate and correction rate are: 1.9X sidereal for the R.A. Up, 0.1X sidereal for the R.A. Down and 13.5 arc sec/sec for the Dec. UP or Down.

*R.A. Down

Set the mode switch in the NS position and press the button S4 while holding down the button S1. Everytime the S4 is pressed, the R.A. correcting up speed will be reduced from 1.9X to 1.1X by 0.1X increments and the R.A. slow down will be 0.9X sidereal from 0.1X sidereal on increments of 0.1X.

*R.A. Speed Up

Set the mode switch in the NS position and press the button S3 while holding down the button S1.

*Dec. Slow Down

Set the mode switch in the NS position. Press the button S5 while holding down the button S1. Everytime the button is pressed in this configuration, the Dec. correction

speed will be changed by a factor of 0.1X [1.5 arc sec/sec. to 13.5 arc sec/sec. in the up or down direction.

*Dec. Speed Up

Flip the Driving Mode Switch at the NS position. While holding the button S1, press the button S5. Every time the button S5 is pressed, the motor speeds up by 1.5 arc sec/sec. The maximum speed up will be 13.5 arc sec/sec either on speed-up or slow-down.

■ Star/Sun switching

When the power is on, the R.A. motor is driven at the sidereal rate.

Solar rate: Set the mode switch in the HS position and press the S5 button while holding down the S1 button. To switch the button from the solar rate to the sidereal rate, set the mode switch to HS position and press the button S6 while holding down the button S1.

	Drive Mode	S1	S3	S4	S5	S6
Solar	HS	PUSH			PUSH	
Sidereal	HS	PUSH				PUSH
R.A. Correction	NS	PUSH	PUSH(-)	PUSH(-)		
Dec. Correction	NS	PUSH			PUSH(+)	PUSH(-)

	1	2	3	4	5	6	7	8	9
R.A. Speed Up	1.1	1.2	1.3	1.4	1.5	1.6	1.7	1.8	1.9
R.A. Slow Down	0.9	0.8	0.7	0.6	0.5	0.4	0.3	0.2	0.1
Dec.	1.5	3.0	4.5	6.0	7.5	9.0	10.5	12.0	13.5

R.A. : To Sidereal Rate
Dec. : Sec.Arc/Sec

■ Auto Guide Connector

The connector for the auto guide device such as SBIG ST-4 is provided on the panel board. The auto guide device is attached to the visual back of a telescope and can watch a guiding star under surveillance on behalf of human eye. When the guiding star would move from the given position, the auto guide device can correct automatically the position of star to the original position.

When the auto guide device is used, use the connecting cable optionally available. Now the cables for SBIG ST-4, ST-7, and STV are available from Takahashi.

⚠ Caution

In case the trouble should be caused by self-rework using the connector or by self-made device, the warranty will be void.

This connector can only actuate the motor in accordance with the signals from the auto guider and cannot ensure the accuracy of the guiding.

■ Auto Guide Connector Chart

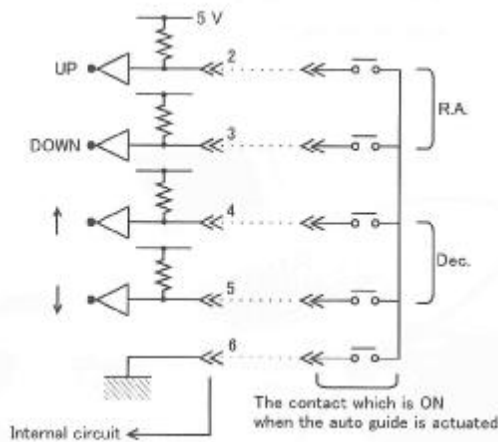

Fig. 36



Receptacle Layout on the Panel Board

Fig. 37